

# PNEUMATIC LIFT TABLE

ERGONOMIC SOLUTIONS



Do not lift more... Care your back! Using our ergonomic

- \* lift tables
- \* Scissors and pneumatics lift tables
- \* Not need hydraulic oil or electricity
- \* Low maintenance!
- \* **5 YEARS WARRANTY**



# SOLUTIONS

Ergonomic lift tables maximize worker and machine productivity by positioning work at an ergonomic height. By eliminating lifting, bending or reaching, these lift tables reduce the risk of back and other work-related injuries. This results in greater quality and productivity as well as lower manufacturing costs and maintenance requirements.

**CORMAC INDUSTRIAL®** offers a complete line of scissor lift tables with optional tilt and rotate platform.

The scissors and all elements are designed rough use, constructed of steel plate and precision machined for uniform operation. We have been manufacturing lift tables since 1999. The standard capacities of lift tables range from 1,000 up to 6,000 lbs.

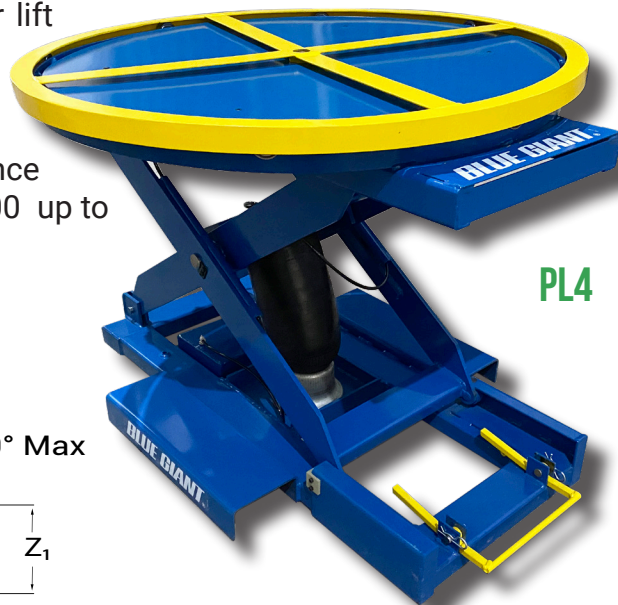
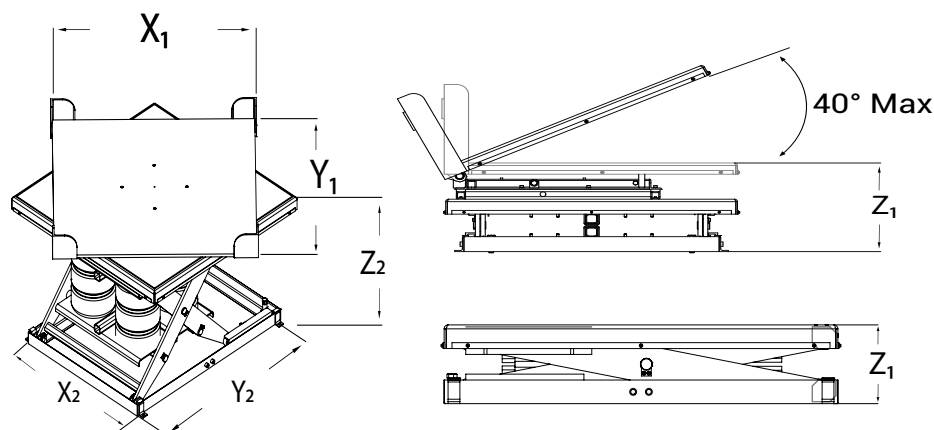

**PL4**

### Self-Contained

Captive air system eliminates the need for constant air hookup or cumbersome mechanical springs

### LIFT TABLE



Lift Table Model #	Nominal capacity	Closed (Z <sub>1</sub> )	Extended (Z <sub>2</sub> )	Base size (X <sub>2</sub> X <sub>Y2</sub> )	Platform size (X <sub>1</sub> x Y <sub>1</sub> )
LE33850A	3000 lbs	10"	34"	38" x 50"	38" x 50"
LE34860A	3000 lbs	10"	34"	38" x 50"	48" x 60"
LE63850A	6000 lbs	10"	34"	38" x 50"	38" x 50"
LE64860A	6000 lbs	10"	34"	38" x 50"	48" x 60"
LE34262B	3000 lbs	11"	45"	42" X 62"	42" X 62"
LE35684B	3000 lbs	11"	45"	42" X 62"	56" x 84"
LE64262B	6000 lbs	11"	40"	42" X 62"	42" X 62"
LE55684B	5000 lbs	11"	40"	42" X 62"	56" x 84"
LE65050A	6000 lbs	10"	34"	38" x 50"	50" X 50"
LE35050A	3000 lbs	10"	34"	38" x 50"	50" X 50"

# SOLUTIONS

## ZERO GROUND LEVEL SCISSOR



Model Number	Load Capacity	Platform Size	Overall Dimensions	Lowered Height	Standard Motor	Weight
ZPL-20 SERIES LIFTS – 36" TRAVEL						
ZPL-20-4448	2,000 lb (907 kg)	44" x 48" (1,118 x 1,219 mm)	72" x 56" (1,829 x 1,422 mm)	3/8" (10 mm)	1 HP	1,300 lb (590 kg)
ZPL-20-5048		50" x 48" (1,270 x 1,219 mm)	74" x 56" (1,880 x 1,422 mm)			1,400 lb (635 kg)
ZPL-40 SERIES LIFTS – 36" TRAVEL						
ZPL-40-4448	4,000 lb (1,814 kg)	44" x 48" (1,118 x 1,219 mm)	72" x 56" (1,829 x 1,422 mm)	1/2" (13 mm)	1 HP	1,325 lb (601 kg)
ZPL-40-5048		50" x 48" (1,270 x 1,219 mm)	74" x 56" (1,880 x 1,422 mm)			1,425 lb (646 kg)

Turn Table Model	Nominal capacity	(Z <sub>1</sub> ) Ref.	Rotation	Turn table size (X <sub>1</sub> x Y <sub>1</sub> ) Ref.
RB43850X	4000 lbs	3.5"	360°	38" x 50"
RB44860X	4000 lbs	3.5"	360°	48" x 60"
RB44262X	4000 lbs	3.5"	360°	42" X 62"
RB45050X	4000 lbs	3.5"	360°	50" X 50"

## TURN TABLE



## LIFT & TURN TABLE



Lift & Turn table	Nominal capacity	(Z <sub>1</sub> ) Ref.	Extended (Z <sub>2</sub> )	Rotation	Table Reference	Platform size of Turn table (X <sub>1</sub> x Y <sub>1</sub> ) Ref.
RL43850A	4000 lbs	13.5"	37.5"	360°	LE63850A	38" x 50"
RL44860A	4000 lbs	13.5"	37.5"	360°	LE64860A	48" x 60"
RL44262B	4000 lbs	14.5"	48.5"	360°	LE64262B	42" X 62"
RL45050A	4000 lbs	13.5"	37.5"	360°	LE55050A	50" X 50"

# SOLUTIONS

Tilt Table model	Nominal capacity	(Z <sub>1</sub> ) Ref.	Tilt (Degrees)	Platform size of Tilt table (X1 x Y1) ref.
TE33850X	3000 lbs	5"	0° - 40°	38" x 50"
TE34860X	3000 lbs	5"	0° - 40°	48" x 60"
TE63850X	6000 lbs	5"	0° - 40°	38" x 50"
TE44860X	4000 lbs	5"	0° - 40°	48" x 60"
TE15684X	1000 lbs	5"	0° - 40°	56" X 84"
TE25684X	2000 lbs	5"	0° - 40°	56" X 84"
TE65050X	6000 lbs	5"	0° - 40°	50" X 50"
TE35050X	3000 lbs	5"	0° - 40°	50" X 50"



**TILT TABLE**

## LIFT & TILT TABLE



Lift & Tilt Table model	Nominal capacity	(Z <sub>1</sub> ) Ref.	Extended (Z <sub>2</sub> )	Tilt (Degrees)	Table Reference	Platform size of Tilt table (X1 x Y1) ref.
TL33850A	3000 lbs	15"	40"	0° - 40°	LE33850A	38" x 50"
TL34860A	3000 lbs	15"	40"	0° - 40°	LE34860A	48" x 60"
TL63850A	6000 lbs	15"	40"	0° - 40°	LE63850A	38" x 50"
TL44860A	4000 lbs	15"	40"	0° - 40°	LE64860A	48" x 60"
TL 156848	1000 lbs	15"	40"	0° - 40°	LE35684B	56" X 84"
TL25684B	2000 lbs	15"	40"	0° - 40°	LE35684B	56" X 84"
TL65050A	6000 lbs	15"	40"	0° - 40°	LE65050A	50" X 50"
TL35050A	3000 lbs	15"	40"	0° - 40°	LE35050A	50" X 50"

**Cormac Industrial**, has been a leading manufacturer and provider of innovative industrial ergonomic lift assist equipment, including air balancers, jib cranes, overhead enclosed monorail systems, pneumatic lift tables, and lift assist systems.

We have been the leader in the development and manufacturing of the best industrial ergonomic equipment in Mexico for more than 34 years. We have designed, manufactured, and installed nearly a thousand lift assist systems over the past 34 years, with nearly 90% of them delivered to the automotive and transportation industries in Mexico. The ergonomic design of our devices makes it easier for the operator to carry out his work with natural movements, eliminating unnecessary efforts, avoiding risks of back and limb injuries.

Our design and manufacturing facilities are located in San Juan del Río Querétaro. We manufacture our own ergonomic aluminum rail systems. We extruded our aluminum rails in Mexico and maintain inventories at Cormac and Blue Giant in Kentucky. Our technology is tried and proven. We cover the entire Mexican territory and North America directly and through value-added distributors. In September 2022 Blue Giant Corporation acquired controlling interest in Cormac Industrial, bringing with it a wealth of resources that will allow us to grow. Together we will be able to expand our offering and footprint to help our national and international customers solve their Ergonomic material handling pains.

[www.cormac-ind.com](http://www.cormac-ind.com)

Tel: 55 8000 6540 / 55 8000 6536 / [sales@cormac-ind.com](mailto:sales@cormac-ind.com)

CORMACIND, S. DE R.L. DE C.V. Av. Benito Juárez 72, San Pedro Ahuacatlán C.P. 76810 San Juan del Río, Querétaro, México